



Winner of the Best Product Award in the Infrastructure category

HotLok Blanking Panel



Purpose

The HotLok® Blanking Panel is a snap-in blanking panel that provides a 99.97%+ effective seal in IT equipment cabinets. The state-of-the-art technology, designed for both 1U and 2U openings, controls airflow for optimized cooling effectiveness.

HotLok Blanking Panel is Upsite's latest green solution for energy savings and reducing the carbon footprint of data centers.

Both 1U- and 2U-configured versions achieve the following:

- Reduce hotspots and bypass airflow by preventing equipment exhaust air or hot-aisle air from migrating to the conditioned air-intake stream at the front of the cabinet
- Deliver lower temperature conditioned air to the upper one-third of the cabinet, typically the hottest area and most prone to equipment failure
- Control airflow to save energy by adjusting cooling unit setpoints

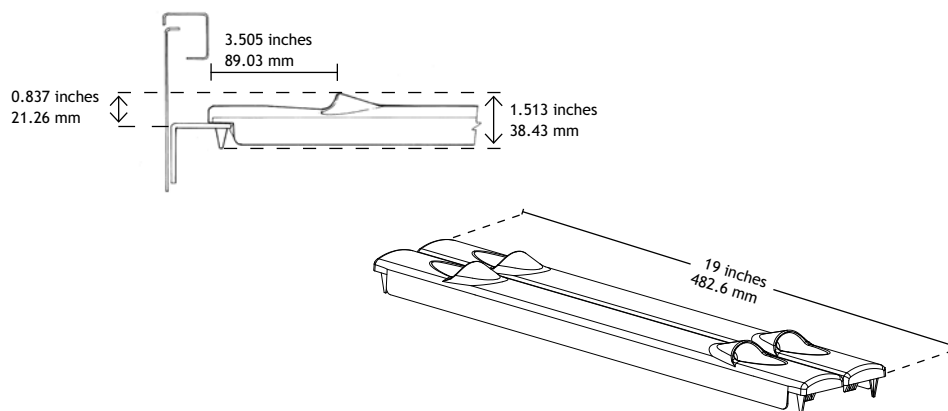

Key Features

- Snap-spring design offers durable, 99.97%+ effective seal
- Tool-free, snap-in installation and easy-pull removal for any EIA-310-E standard openings using ergonomically designed finger grips
- Cantilevered sealing vanes eliminate the gap between adjoining Blanking Panels or with installed equipment
- 1U Panels stack 10 high and 2U Panels stack 20 high for easy storage and ready availability

Applications

- Use 1U and 2U versions on cabinets with standard 19-inch rail widths (483 millimeter)
- Use with any standard EIA-310-E openings
- Use in a Hot and Cold Aisle layout for low or high heat density cabinets
- Use in existing cabinets for optimization and standardization

designed and
manufactured by
upsite
technologies®

upsite.com
upsite corporate headquarters
santa fe, new mexico usa
505.982.7800

Upsite is an ENERGY STAR Service and Product Provider Partner,
developing ways to optimize data centers
and improve energy efficiency.



upsite europe
utrecht, netherlands
+31 (0)30 7523670



Base Product	Rack Rail Opening	Item Number	Quantity, Item Name
HotLok® 1U Blanking Panel	9.5mm Square	10015	Carton (10 Each) HotLok® 1U Blanking Panels - 9.5mm Square
	M5/10-32 Round	10031	Carton (10 Each) HotLok® 1U Blanking Panels - M5/10-32 Round
	M6/12-24 Round	10041	Carton (10 Each) HotLok® 1U Blanking Panels - M6/12-24 Round
HotLok® 2U Blanking Panel	9.5mm Square	10023	Carton (5 Each) HotLok® 2U Blanking Panels - 9.5mm Square
	M5/10-32 Round	10033	Carton (5 Each) HotLok® 2U Blanking Panels - M5/10-32 Round
	M6/12-24 Round	10043	Carton (5 Each) HotLok® 2U Blanking Panels - M6/12-24 Round

Patent Pending Design

U.S. design patent number D577,360. Utility and international patents pending.

Certifications and Conformance

RoHS Compliant: HotLok Blanking Panels are made of blended acrylonitrile butadiene styrene (ABS) that does not contain bromic compounds that have been found to be environmentally harmful.

Recyclable: The product is made with some recycled ABS and the resulting product is recyclable. In addition, all packaging is made with some post-consumer recycled content and is 100 percent recyclable.

Fire-resistant: Made of resins that are UL-Recognized with a V-O flame rating, UL File Number E56070.

Warranty

HotLok Blanking Panels have a warranty for 12 months upon purchase date. The warranty can be extended from 12 to 28 months by registering the purchase online at upsite.com/warranty.